

use & care guide

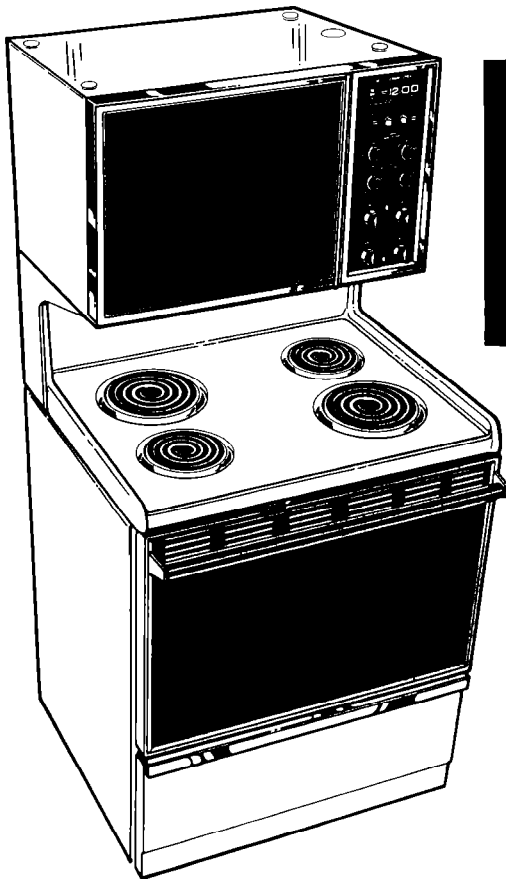

ELECTRIC RANGE

Model
RE960PXV

ers. Clothes Dryers. Freezers. Refrigerator-Freezers. Ice Makers. Dishwashers. Built-In Ovens and Surface Units. Ranges. Microwave Ovens. Trash Compact

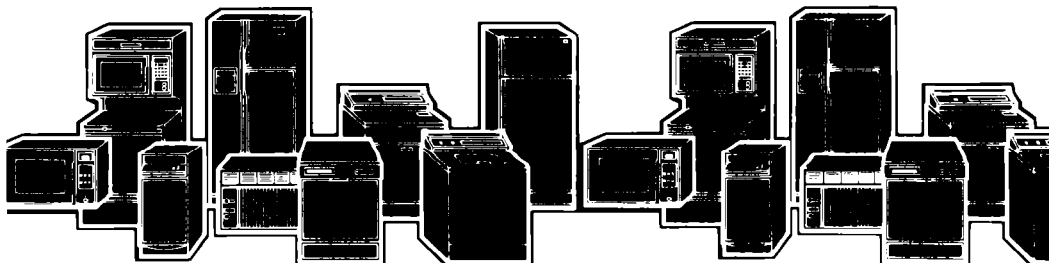

Contents		Page	Page
BEFORE YOU USE YOUR RANGE		2	CARING FOR YOUR RANGE 15
IMPORTANT SAFETY			Control Panel and Knobs 15
INSTRUCTIONS	3		Surface Units and Reflector Bowls 16
PARTS AND FEATURES	5		Lift-Up Cooktop 18
USING YOUR RANGE	6		The Upper Oven Rack Guides 18
Using the Surface Units	6		The Continuous-Cleaning Upper Oven 19
Optional Canning Kit	7		Using the Self-Cleaning Cycle 21
Setting the Clock	8		Cleaning Chart 24
Using the Minute Timer	8		Using and Replacing the Light Bulbs 26
Using the Oven Controls	9		The Cooktop Light 26
Baking	9		The Oven Lights 27
Adjusting the Oven Temperature Controls	10		IF YOU NEED SERVICE
Broiling	11		OR ASSISTANCE 29
Using the Automatic MEALTIMER™ Clock	12		WHIRLPOOL RANGE
The Oven Vent	13		WARRANTY 32
The Storage Drawer	14		
Optional Rotisserie	15		
Optional Door Panel Pac	15		

©1989 Whirlpool Corporation

Before you use your range

You are responsible for:

- Reading and following all safety precautions in this Use and Care Guide and the Cooking Guide.
- Installing and leveling the range on a floor strong enough to hold its weight, and where it is protected from the elements. (See the Installation Instructions.)
- Making sure the range is not used by anyone unable to operate it properly.
- Properly maintaining the range.
- Using the range only for jobs expected of a home range.

Remove the Consumer Buy Guide label. It will be easier to remove before the range is used. To remove any remaining glue:

- Rub briskly with thumb to make a ball, then remove.
or
- Soak area with liquid hand dishwashing detergent before removing glue as described above.

Do not use rubbing alcohol or flammable or toxic solvents, such as acetone, gasoline, carbon tetrachloride, etc. These can damage the finish.

IMPORTANT SAFETY INSTRUCTIONS

⚠️ WARNING

To reduce the risk of fire, electrical shock, injury to persons, or damage when using the range, follow basic precautions, including the following:

- Read all instructions before using the range.
- Install or locate the range only in accordance with the provided Installation Instructions. It is recommended that the range be installed by a qualified installer. *The range must be properly connected to electrical supply and grounded.*
- Do not use the range for warming or heating the room. Persons could be burned or injured, or a fire could start.
- Do not leave children alone or unattended in area where the range is in use. They should never be allowed to sit or stand on any part of the range. They could be burned or injured.
- Do not wear loose or hanging garments when using the range. They could ignite if they touch a hot surface unit or heating element and you could be burned.
- Do not repair or replace any part of the range unless specifically recommended in this manual. All other servicing should be referred to a qualified technician.
- Do not store flammable materials in or near the range. They could explode or burn.
- Do not use water on grease fires. Never pick up a flaming pan. Smother flaming pan on cooktop by covering with a well-fitted lid, cookie sheet or flat tray. Flaming grease outside of pan can be extinguished with baking soda or, if available, a multipurpose dry chemical or foam-type extinguisher.
- Use only dry potholders. Moist or damp potholders on hot surfaces may result in burns from steam. Do not let potholder touch hot heating elements. Do not use a towel or bulky cloth for a potholder. They could catch on fire.
- Select a pan with a flat bottom that is about the same size as the surface unit. If pan is smaller than the surface unit, some of the heating element will be exposed and may result in the igniting of clothing or potholders. Correct pan size also improves cooking efficiency.
- Never leave surface units unattended at high heat settings. A boil-over could result and cause smoking and greasy spill-overs that may ignite.
- Make sure the reflector bowls are in place during cooking. Cooking without reflector bowls may subject the wiring and components underneath them to damage.
- Do not line reflector bowls with aluminum foil or other liners. Improper installation of these liners may result in a risk of electric shock or fire.
- Check to be sure glass cooking utensils are safe for use on the cooktop. Only certain types of glass, glass ceramic, ceramic, earthenware or other glazed utensils are suitable for cooktops without breaking due to the sudden change in temperature.
- Turn pan handles inward, but not over other surface units. This will help reduce the chance of burns, igniting of flammable materials, and spills due to bumping of the pan.
- Do not soak removable heating elements in water. The element

will be damaged and shock or fire could result.

- Use care when opening oven door. Let hot air or steam escape before removing or replacing food.
- Do not heat unopened containers. They could explode. The hot contents could cause burns and container particles could cause injury.
- Keep range vents unobstructed.
- Always position oven racks in desired location while oven is cool. If rack must be moved while oven is hot, do not let potholder contact hot heating element in oven.
- Do not clean door seal. It is essential for a good seal. Care should be taken not to rub, damage, or move the seal. Clean only parts recommended in this Use and Care Guide.
- Do not use oven cleaners. No commercial oven cleaner or oven liner protective coating of any kind should be used in or around any part of the oven.
- Before self-cleaning the lower oven, remove broiler pan, broiler grid, oven racks and other utensils. Do not use your oven to clean miscellaneous parts.

- Do not store things children might want above the range. Children could be burned or injured while climbing on it.
- Do not touch surface units, areas near units, heating elements or interior surfaces of oven. Surface units and heating elements may be hot even though they are dark in color. Areas near surface units and interior surfaces of an oven become hot enough to cause burns. During and after use, do not touch, or let clothing or other flammable materials contact surface units, areas near units, heating elements or interior surfaces of oven until they have had sufficient time to cool. Other surfaces of the range may become hot enough to cause burns; such as, the oven vent opening, the surface near the vent opening, the cooktop, the oven door and window.

• **FOR YOUR SAFETY** •

DO NOT STORE OR USE GASOLINE OR OTHER FLAMMABLE VAPORS AND LIQUIDS IN THE VICINITY OF THIS OR ANY OTHER APPLIANCE. THE FUMES CAN CREATE A FIRE HAZARD OR EXPLOSION.

– **SAVE THESE INSTRUCTIONS** –

Thank you for buying a Whirlpool appliance. Please complete and mail the Owner Registration Card provided with this product. Then complete the form below. Have this information ready if you need service or call with a question.

- Copy model and serial numbers from plate (behind the oven door on the oven frame) and purchase date from sales slip.
- Keep this book, the Cooking Guide and sales slip together in a handy place.

_____ **Model Number**

_____ **Serial Number**

_____ **Purchase Date**

_____ **Service Company Phone Number**

Parts and features

Model RE960PXV

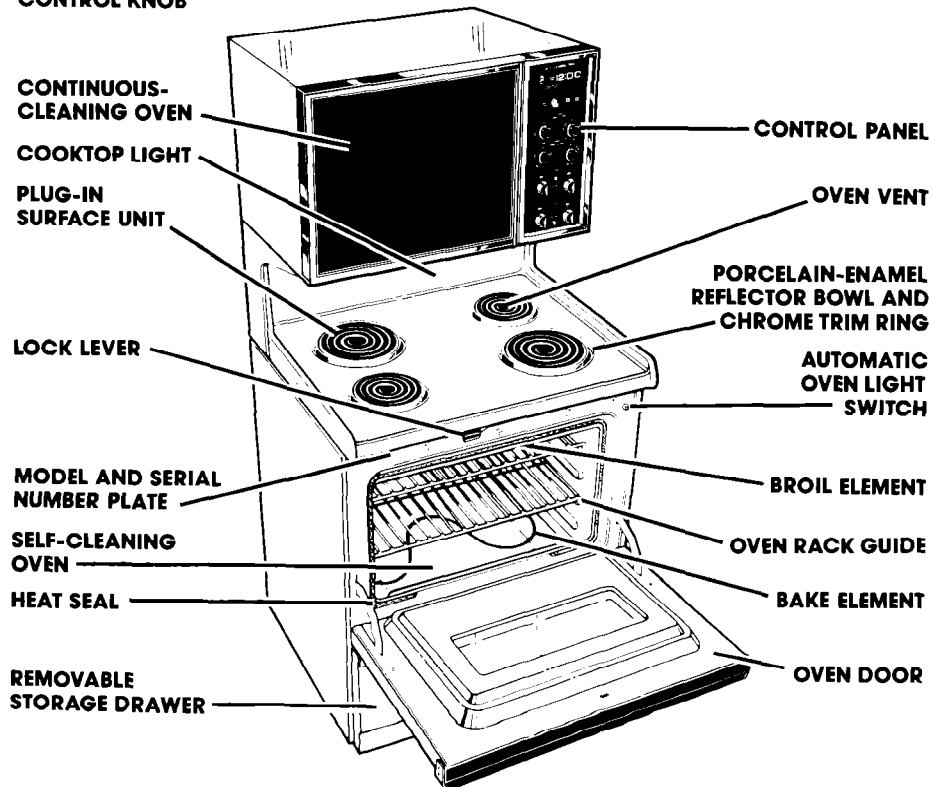
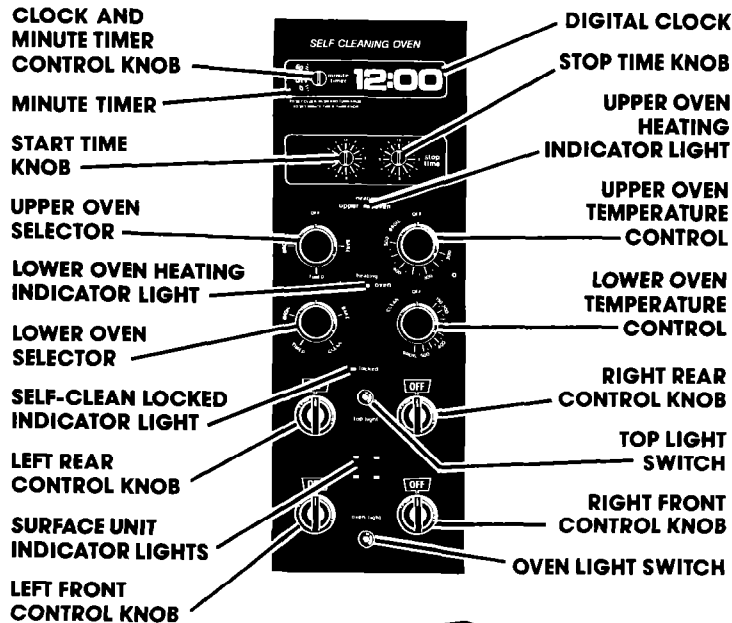

Using your range

Using the Surface Units

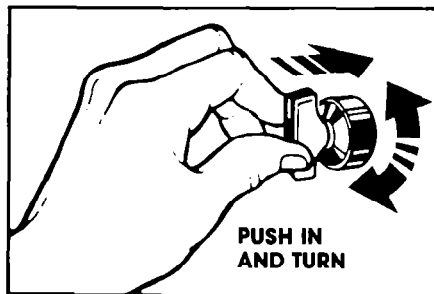

Surface unit control knobs must be pushed in before turning. Turn either way until setting you want shows in the window. Set them anywhere between HI and LOW.

Surface Unit Indicator Lights

One of the surface unit indicator lights on the control panel will glow when a surface unit is on.

⚠ WARNING

Burn and Fire Hazard

Be sure all control knobs are turned to OFF and all indicator lights are OFF when you are not cooking. Someone could be burned or a fire could start if a surface unit is accidentally left ON.

Until you get used to the settings, use the following as a guide. For best results, start cooking at the high settings; then turn the control knob down to continue cooking.

Use HI to start foods cooking; to bring liquids to a boil.

Use MED-HI to hold a rapid boil; to fry chicken or pancakes.

Use MED for gravy, puddings and icing; to cook large amounts of vegetables.

Use MED-LO to keep food cooking after starting it on a higher setting.

Use LO to keep food warm until ready to serve. Set the heat higher or lower within the LO band to keep food at the temperature you want.

Use only flat-bottomed utensils for best cooking results and to prevent damage to the cooktop. Specialty items with rounded or ridged bottoms (woks, ridged bottom canners or tea kettles) are not recommended.

⚠ WARNING

Burn and Product Damage Hazard

- **If the pan is too small for the surface unit, you could be burned by the heat from the exposed section of the surface unit. Use correctly sized cooking utensils to prevent injury.**
- **If a surface unit stays red for a long time, the bottom of the pan is not flat enough or is too small for the surface unit. Prolonged usage of incorrect utensils for long periods of time can result in damage to the surface unit, cooktop, wiring and surrounding areas. To prevent damage, use correct utensils, start cooking on HI and turn control down to continue cooking.**

See the Cooking Guide for additional utensil information.

Optional Canning Kit (Part No. 242905)

The large diameter of most water-bath or pressure canners combined with high heat settings for long periods of time can shorten the life of regular surface units and cause damage to the cooktop.

If you plan to use the cooktop for canning, we recommend the installation of a Canning Kit. Order the kit from your Whirlpool dealer or authorized WhirlpoolSM service company.

See the Cooking Guide for additional canning information.

Setting the Clock

Push in and turn the Minute Timer Knob to set the Clock.



1. Push in Minute Timer Knob and turn clockwise until clock shows the right time of day.



2. Let the Minute Timer Knob pop out. Turn counterclockwise until the Minute Timer dial is on OFF. The clock setting will change if you push in the knob when turning.

Using the Minute Timer

The Minute Timer does not start or stop the oven. It works like a kitchen timer. Set it in minutes up to an hour. You will hear a buzzer when the set time is up.

DO NOT PUSH IN THE KNOB when setting the Minute Timer.

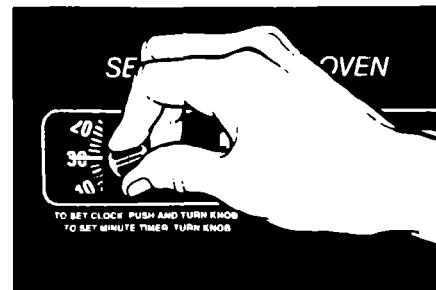

1. Without pushing it in, turn the Minute Timer Knob until the time in the window passes the setting you want.

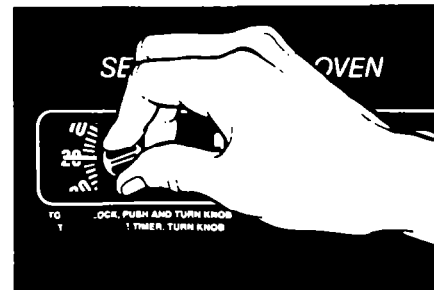

2. Without pushing in, turn the knob back to the setting you want. When the time is up, a buzzer will sound. To stop the buzzer, turn the Minute Timer dial to OFF.

PUSHING IN AND TURNING THE MINUTE TIMER KNOB CHANGES THE CLOCK SETTING.

Using the Oven Controls

Baking in Either Oven

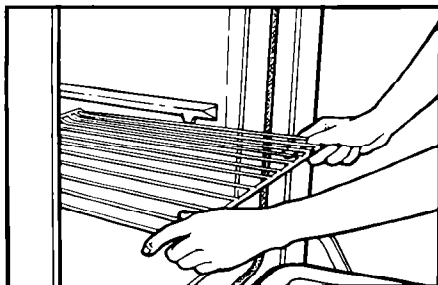

The rack(s) should be placed so the top of the food will be centered in the oven. Always leave at least 1½ to 2 inches (4-5 cm) between the sides of the pan and the oven walls and other pans. For more information, see the Cooking Guide.

1. Position the rack(s) properly **before** turning on the oven. **To change rack position, lift rack at front and pull out.**

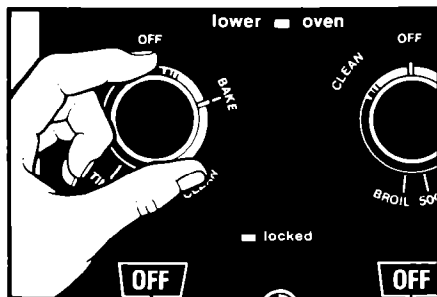

2. Set the Oven Selector to BAKE.

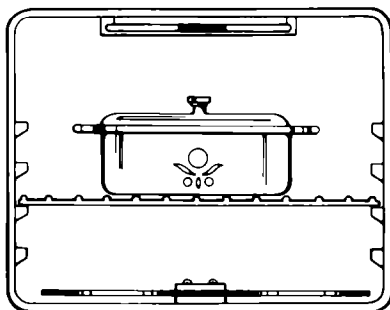

4. Put food in the oven. During baking, the elements will turn on and off to keep the oven temperature at the setting. The HEATING Indicator Light will turn on and off with the elements.

The top element helps heat during baking, but does not turn red.

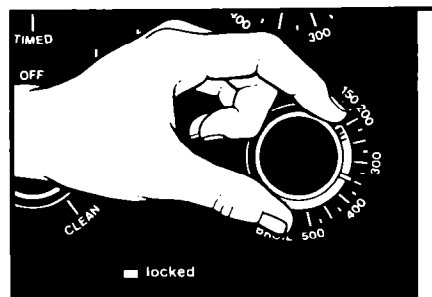

3. Set the Oven Temperature Control to the baking temperature you want. The HEATING Indicator Light will come on. The oven is preheated when the HEATING Indicator Light first goes off.



5. When baking is done, turn both the Oven Selector and Oven Temperature Control to OFF.

Adjusting the Oven Temperature Controls

Does your oven seem hotter or colder than your old oven? The temperature of your old oven may have shifted gradually without you noticing the change. Your new oven is properly adjusted to provide accurate temperatures. But, when compared to your old oven, the new design may give you different results.

If after using the oven for a period of time, you are not satisfied with the temperature settings, they can be adjusted by following these steps:

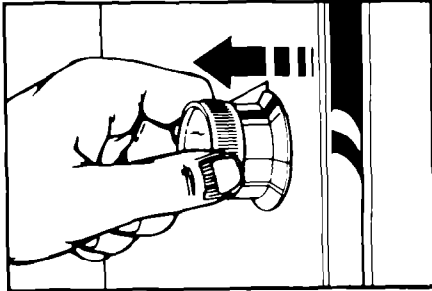

1. Pull one or both of the Oven Temperature Control Knobs straight off.

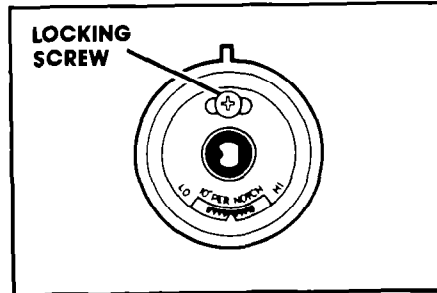

2. Loosen the locking screw inside the control knob. **Note the position of the notches.**

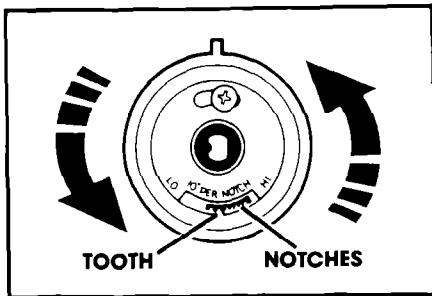

3. **To lower the temperature**, move the tooth a notch closer to LO. Each notch equals about 10°F (5°C).

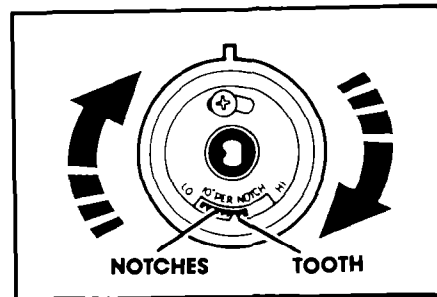

4. **To raise the temperature**, move the tooth a notch closer to HI. Each notch equals about 10°F (5°C).

Tighten the locking screw and replace the control knob.

Broiling in Either Oven

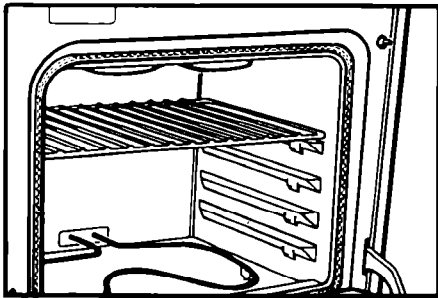

1. Position the rack before turning the oven on. See "Broil Chart" in the Cooking Guide or a reliable cookbook for recommended rack positions.

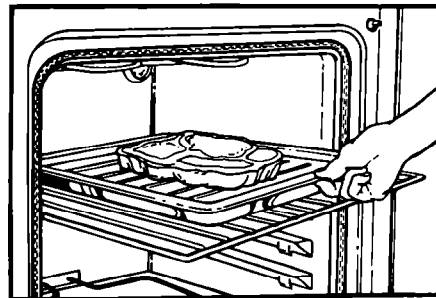

2. Put the broiler pan and food on the rack.

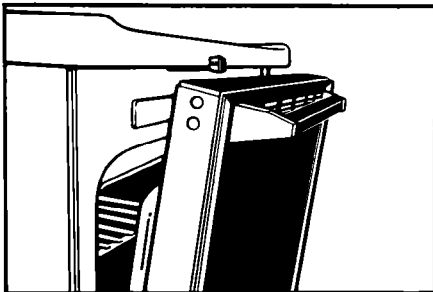

3. Close the door to the Broil Stop position (open about 4 inches, 10.2 cm). The door will stay open by itself.

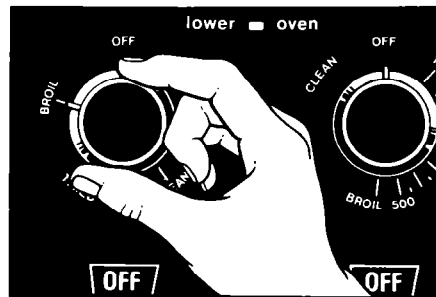

4. Set the Oven Selector and Oven Temperature Control to BROIL. The HEATING Indicator Light will come on.
5. When broiling is done, turn **both** the Oven Selector and Oven Temperature Control to OFF. The HEATING Indicator Light will go OFF.

Custom Broil

- If food is cooking too fast, turn the Oven Temperature Control **counterclockwise** until the HEATING Indicator Light goes off.
- If you want the food to broil slower from the start, set the Oven Temperature Control between 150° and 325°F (65.5° and 162.7°C). The lower the temperature, the slower the cooking.

NOTE: The door must be partly open whenever the oven is set to BROIL. Leaving the door open allows the oven to maintain proper temperatures.

Using the Automatic MEALTIMER™ Clock

The automatic MEALTIMER™ Clock is designed to turn the lower oven on and off at times you set, even when you are not around.

Automatic baking is ideal for foods which do not require a preheated oven, such as meats and casseroles. **Do not use the automatic cycle for cakes, cookies, etc...undercooking will result.**

To delay start and stop automatically:

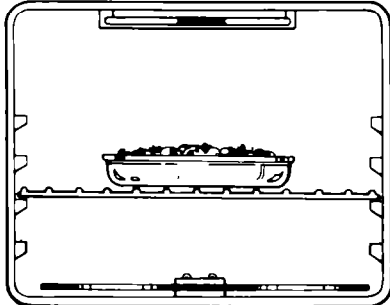

1. Position the oven rack(s) properly and place the food in the oven.

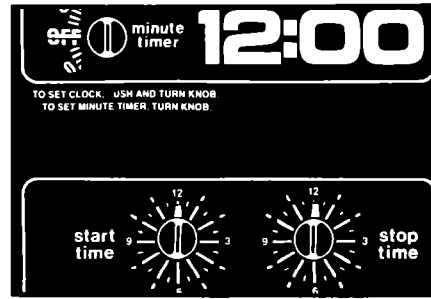

2. Make sure the clock is set to the right time of day.

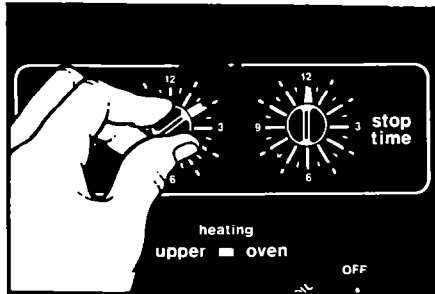

3. Push in and turn the Start Time Knob **clockwise** to the time you want baking to start.

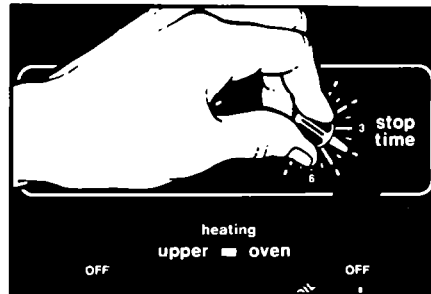

4. Push in and turn the Stop Time Knob **clockwise** to the time you want the oven to shut off.

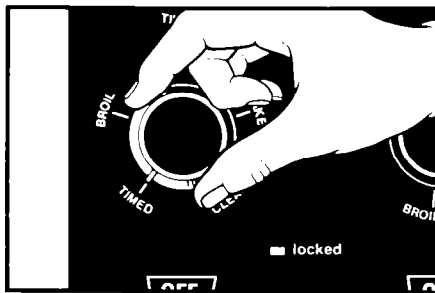

5. Set the Oven Selector on TIMED.

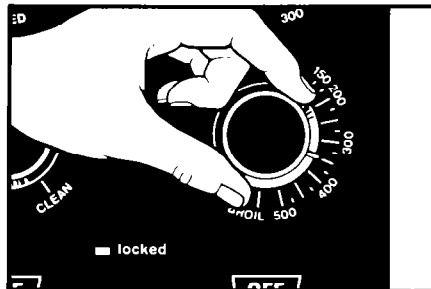

6. Set the Oven Temperature Control on the baking temperature you want. The oven will now start and stop automatically.
After baking is done or to stop the oven before preset time, turn both the Oven Selector and the Oven Temperature Control to OFF.

To start baking now and stop automatically:

1. Position rack(s) properly and place the food in the oven.
2. **Make sure the clock is set to the right time of day.**
3. Push in and turn the Stop Time Knob **clockwise** to the time you want the oven to shut off.
4. Set the Oven Selector on TIMED.
5. Set the Oven Temperature Control on the baking temperature you want.
6. **After baking is done or to stop the oven before the preset time,** turn both the Oven Selector and the Oven Temperature Control to OFF.

⚠ WARNING**To avoid sickness and food waste when using the MEALTIMER™ control:**

- **Do not use foods that will spoil while waiting for cooking to start, such as dishes with milk or eggs, cream soups, and cooked meats or fish. Any food that has to wait for cooking to start should be very cold or frozen before it is put in the oven. MOST UNFROZEN FOODS SHOULD NEVER STAND MORE THAN TWO HOURS BEFORE COOKING STARTS.**
- **Do not use foods containing baking powder or yeast when using delay start. They will not rise properly.**
- **Do not allow food to remain in oven for more than two hours after end of cooking cycle.**

The Oven Vent

Hot air and moisture escape from the oven through a vent under the right rear surface unit. You can cook on the unit, or keep food warm on it while the oven is on.

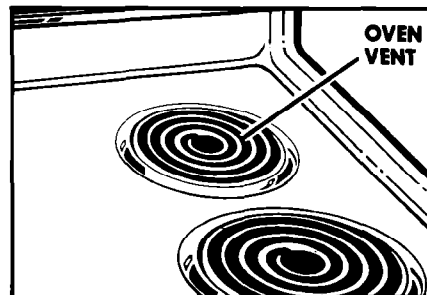

The vent is needed for air circulation. **Do not block the vent.** Poor baking can result.

⚠ WARNING**Burn Hazard**

If you leave a utensil on the right rear surface unit, use potholders when moving it. Pan handles can become hot enough to burn. Plastic utensils left over the vent can melt.

The Storage Drawer

The storage drawer is for storing pots and pans. The drawer can be removed to make it easier to clean under the range.

Use care when handling the drawer.

Removing the storage drawer

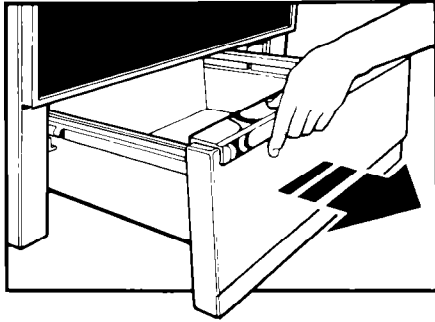

1. Empty drawer of any pots and pans before removing drawer. Pull drawer straight out to the first stop. Lift front and pull out to the second stop.

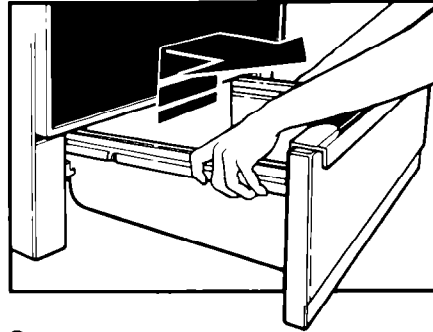

2. Lift back slightly and slide drawer all the way out.

Replacing the storage drawer

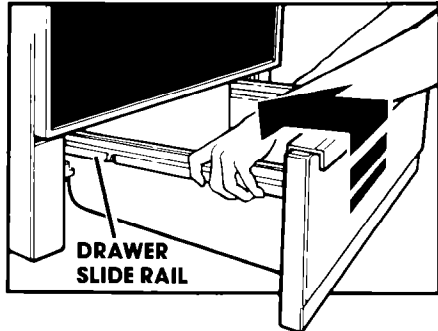

1. Fit ends of drawer slide rails into the drawer guides on both sides of opening.

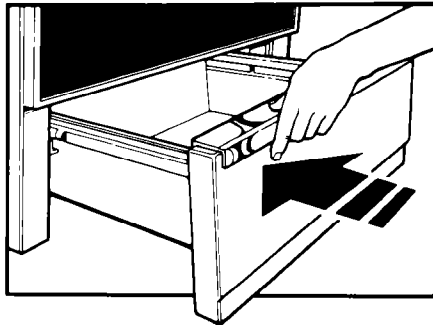

2. Lift drawer front and push in until metal stops on drawer slide rails clear white stops on drawer guides. Lift drawer front again to clear second stop and slide drawer closed.

Optional Rotisserie

If you would like a rotisserie for your lower oven, you can order a kit (Part No. 242985) from your Whirlpool Dealer. The kit includes easy installation instructions.

Optional Door Panel Pac

If you would like to change the color of your lower oven door glass to white or almond, you can order one of these kits: White (Kit No. 814069) or Almond (Kit No. 814070) from your Whirlpool Dealer. The kits include easy installation instructions.

Caring for your range

Control Panel and Knobs

⚠ WARNING

Burn and Electrical Shock Hazard
Make sure all controls are OFF and the range is cool before cleaning. Failure to do so can result in burns or electrical shock.

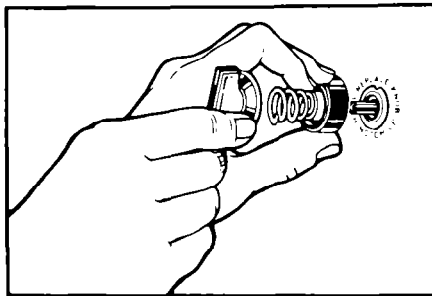

1. Pull knobs straight off. **NOTE: Surface unit control knobs have a collar and a spring behind them.**

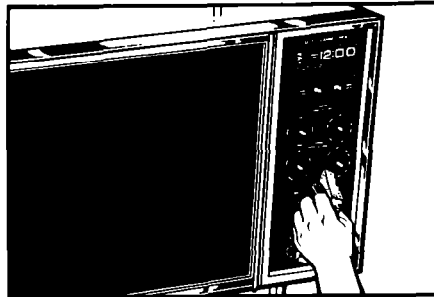

2. Use warm soapy water or spray glass cleaner, and a soft cloth to wipe the control panel. Rinse and wipe dry.

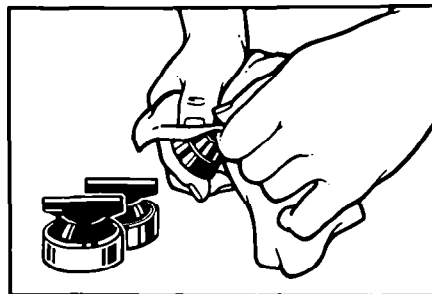

3. Wash control knobs and surface unit collars in warm soapy water. Rinse well and dry. Do not soak.

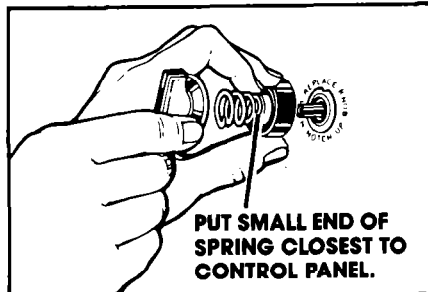

4. Push control knobs straight back on. Make sure they point to OFF. Make sure the collar and spring behind the surface unit control knobs are put together as shown.

Surface Units and Reflector Bowls

Removing

⚠ WARNING

Burn and Electrical Shock Hazard
Make sure all surface units are **OFF** before removing surface units and reflector bowls. Failure to do so can result in burns or electrical shock.

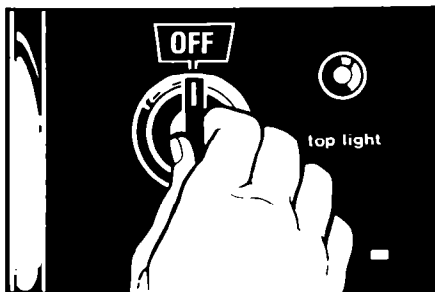

1. Turn off all surface units.

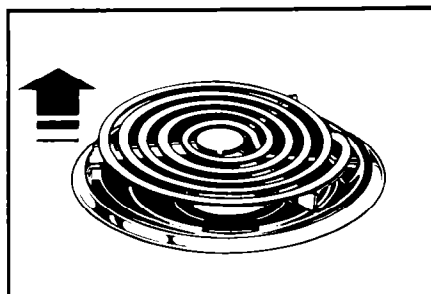

2. Lift the edge of the unit opposite the receptacle, just enough to clear the element hold down clip, reflector bowl and trim ring.

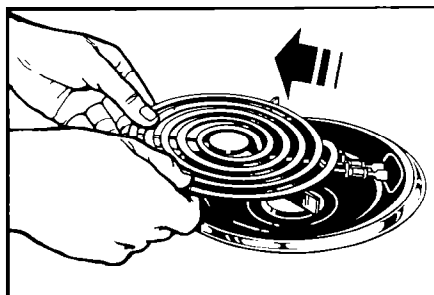

3. Pull the surface unit straight away from the receptacle.

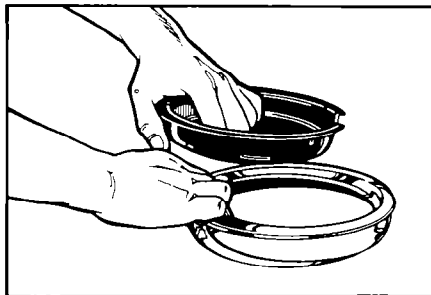

4. Lift out the reflector bowl and trim ring. See "Cleaning Chart" on page 24 for cleaning instructions.

Replacing

⚠ WARNING

Burn, Electrical Shock and Fire Hazard

- Make sure all surface units are OFF before replacing surface units and reflector bowls. Failure to do so can result in burns or electrical shock.
- Do not line the reflector bowls with foil. Fire or electrical shock could result.

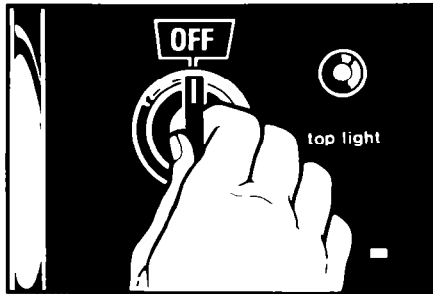

1. Turn off all surface units.



2. Line up openings in the reflector bowl and notch in the trim ring with the surface unit receptacle and the element hold down clip.



3. Hold the surface unit as level as possible with the terminal just started into the receptacle. Push the surface unit terminal into the receptacle.

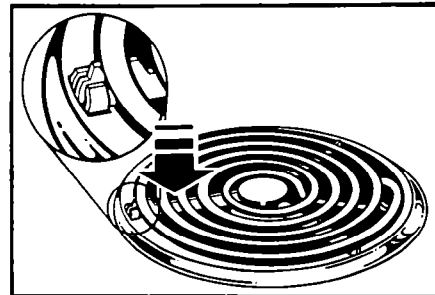

4. When terminal is pushed into the receptacle as far as it will go, push down the edge of the surface unit opposite the receptacle. The element hold down clip will keep the surface unit from moving around.

NOTE: Reflector bowls reflect heat back to the utensils on the surface units. They also help catch spills. When they are kept clean, they reflect heat better and look new longer.

If a trim ring gets discolored, some of the utensils may not be flat enough, or some may be too large for the surface unit. In either case, some of the heat that's meant to go into or around a utensil goes down and heats the trim ring. This extra heat can discolor it. See Cooking Guide for further information.

Lift-Up Cooktop

1. Lift front of cooktop at both front corners until the support rods lock into place.

⚠ WARNING

Personal Injury and Product Damage Hazard

- Be sure both support rods are fully extended and in the locked position. Failure to do so could result in personal injury from the cooktop accidentally falling.
- Do not drop the cooktop. Damage can result to the porcelain and the cooktop frame.

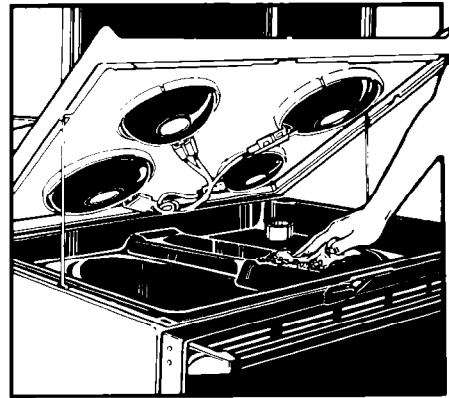

2. Wipe with warm, soapy water. Use a soapy steel wool pad on heavily-soiled areas.
3. To lower the cooktop, lift cooktop from both sides while pressing the support rods back to unlock them. Lower the cooktop into place.

The Upper Oven Rack Guides

Removing the upper oven rack guides will help make it easier to clean the upper oven.

⚠ WARNING

Burn and Electrical Shock Hazard

Make sure all controls are OFF and the oven is cool before removing upper oven rack guides. Failure to do so can result in burns or electrical shock.

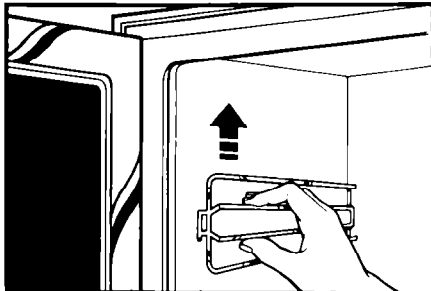

1. Lift the front of the rack guides.

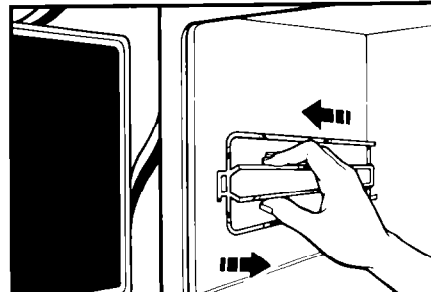

2. Swing the front of the rack guides away from the oven wall far enough so the tab in the guides clears the notch in the oven wall. Pull the guides straight away from the back wall.

REVERSE THE PROCEDURE TO REPLACE RACK GUIDES.

The Continuous-Cleaning Upper Oven

Standard oven walls are coated with smooth porcelain. Your Continuous-Cleaning oven walls are coated with a special, rougher porcelain. A fat spatter beads up on the smooth surface, but spreads out on the rougher surface. The bead of fat on the smooth surface chars and turns black. The spread-out fat on the rough surface **gradually** burns away at **medium to high baking temperatures** so the oven can return to a presentably clean condition.

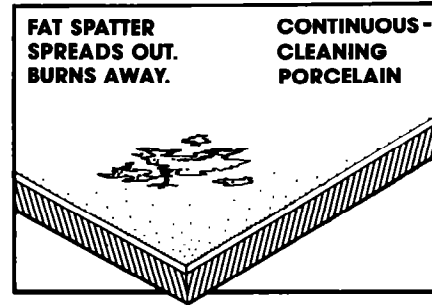
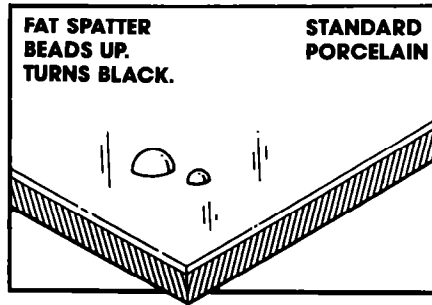

Using Foil

Using foil on the oven bottom is recommended to catch sugar and starchy spills from pies and casseroles. **It must be used properly.** Cut foil from a roll of heavy-duty 18-inch (45 cm) aluminum foil, or buy a foil kit (Part No. 241430) from your Whirlpool Appliance dealer.

⚠ WARNING

Burn, Electrical Shock and Product Damage Hazard

- **Make sure all controls are OFF and the oven is cool before using foil. Failure to do so can result in burns or electrical shock.**
- **Do not let foil touch the bake element. It could damage the element. Make sure foil is flat on the bottom and away from the bake element.**

- 1. Turn off all controls.**
- 2. Lift the cool bake element slightly to lift the feet off the oven bottom.**
- 3. Slide the foil under the bake element.** Make sure the foil is centered, long enough to start up both sides and without wrinkles. For proper baking, **lower the bake element so all feet rest solidly on the foil.**

Cleaning Tips

1. The oven window and racks are not coated. Clean them by hand.
2. The oven door does not get as hot as the walls. Some hand cleaning may be needed.
3. If you do more broiling than baking, hand cleaning may be needed.
4. Use aluminum foil on the oven bottom according to instructions. Spill-overs may not burn away and could stain the bottom.

Hand Cleaning

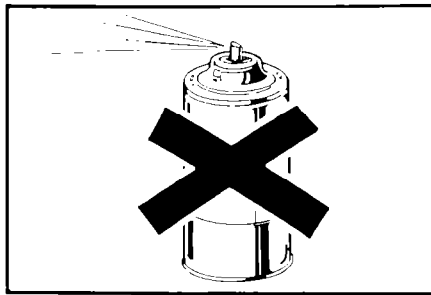

⚠ WARNING

Personal Injury Hazard
Do not use oven cleaning products. Some can become trapped in the porcelain surface and give off harmful fumes.

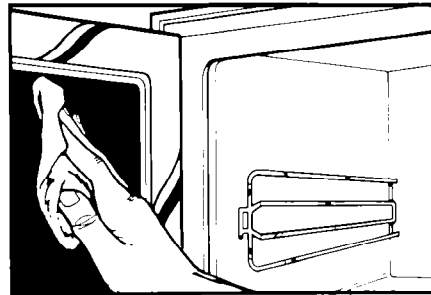

WINDOW – Keep clean with hot soapy water. Use a plastic scrubbing pad for heavily-soiled areas. Rinse well. **Do not use steel wool or abrasive cleansers.**

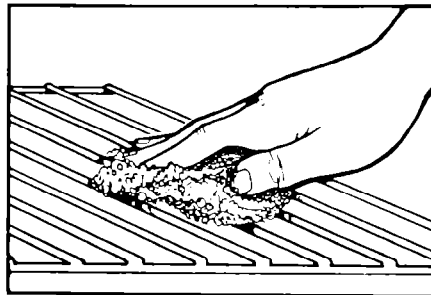

RACKS – Use a soapy steel wool pad for best cleaning results. Rinse well.

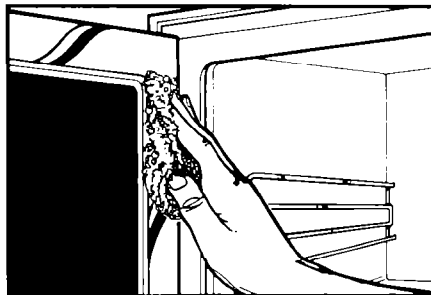

WALLS AND DOOR – Wash with hot soapy water. Use a steel wool pad or plastic scrubbing pad for heavily-soiled areas. Rinse well.

Using the Self-Cleaning Cycle (Lower Oven)

The Self-Cleaning cycle uses **very high heat** to burn away soil. Before you start, make sure you understand exactly how to use the Self-Cleaning cycle safely.

Before You Start

1. Clean the areas shown by hand.

They do not get hot enough during the Self-Cleaning cycle for soil to burn away. Use hot water and detergent or a soapy steel wool pad on...

- The inside of the door. (The center area of the door does not need to be hand cleaned.)
- The frame around the oven.

DO NOT clean, move or bend the fiberglass seal. Poor cleaning and poor baking will result.

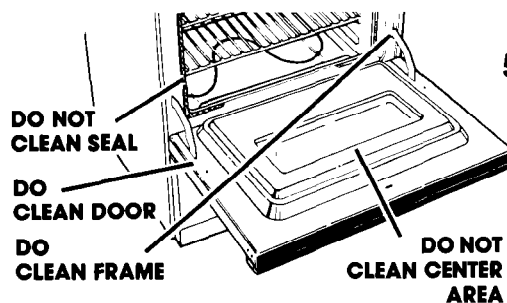

2. Remove the broiler pan and any pots and pans you may have stored in the oven.

NOTE: The broiler pan (without grid) can be cleaned in the oven only if most of the soil has been removed by hand-cleaning or a dishwasher. The chrome broiler grid will discolor if cleaned in the Self-Cleaning cycle.

3. Wipe out any loose soil or grease. This will help reduce smoke during the Self-Cleaning cycle.

4. If the oven has a rotisserie, make sure the motor socket cover is closed.

5. If you want the oven racks to remain shiny, remove from the oven and clean by hand. Otherwise, put oven racks on second and fourth guides (guides are counted from bottom to top). After racks are cleaned in the Self-Cleaning cycle, they become harder to slide. See chart on page 24.

6. If you want to clean the reflector bowls in the oven:

- Wipe the reflector bowls of loose soil and grease.
- Place 2 bowls, upside down on each oven rack. For best results, they should not touch each other or the oven walls.
- **Chrome trim rings must not be cleaned in the oven. They will discolor.**

Turn on the vent hood or other kitchen vent during the Self-Cleaning cycle. This will help remove heat and odors that are normal during the cycle.

⚠ WARNING

Personal Injury and Product Damage Hazard

- **Do not touch the oven during the Self-Cleaning cycle. It could burn you.**
- **Do not use commercial oven cleaners in your oven. Cleaners may produce hazardous fumes or damage the porcelain finish.**
- **Do not force the Lock Lever, you could bend or break it. The lever is designed to stay locked until the oven is cool enough to safely open. Wait until it moves freely.**
- **Do not use foil or other liners in the oven. During the Self-Cleaning cycle foil can burn or melt and damage the oven surface.**
- **Do not block the vent during the Self-Cleaning cycle. Air must move freely for best cleaning results.**
- **Do not leave plastic utensils near the vent. They may melt.**

Setting the Controls

Be sure the kitchen is ventilated during the Self-Cleaning cycle. This will help heat, odors and smoke to disappear from the room as quickly as possible.

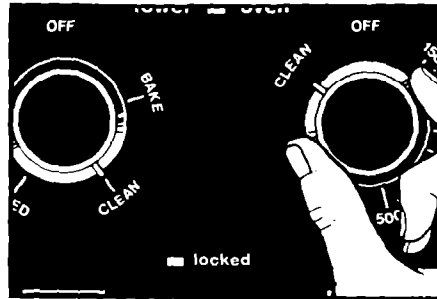

1. Set the Oven Selector and the Oven Temperature Control on CLEAN.

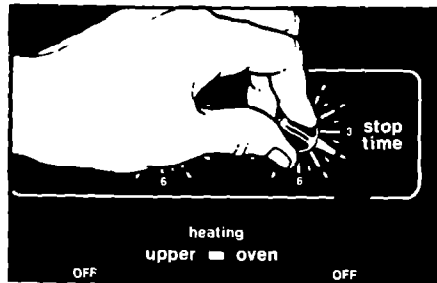

3. Push in and turn the Stop Time Knob **clockwise** 2 or 3 hours.
 - Use 2 hours for light soil.
 - Use 3 hours or more for moderate to heavy soil.

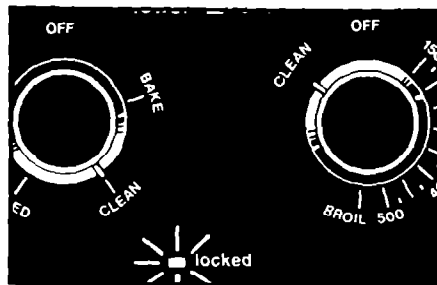

5. The LOCKED Indicator Light will come on when the oven temperature exceeds normal baking temperatures. The Lock Lever must not be moved and the door can't be opened when the LOCKED Indicator Light is on.

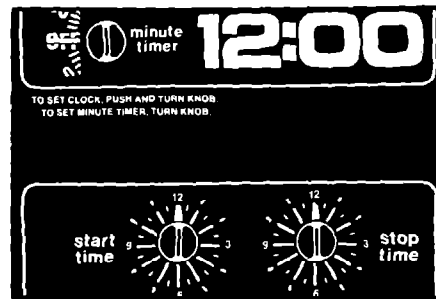

2. Make sure the Clock, Start and Stop Times all have the right time of day.

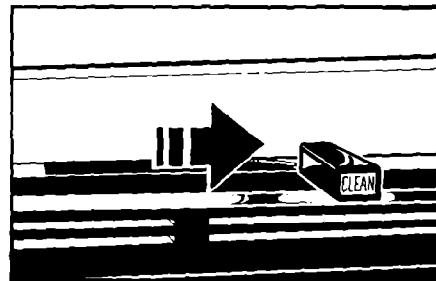

4. Move the Lock Lever to the right – the Clean position. The HEATING Indicator Light will come on.

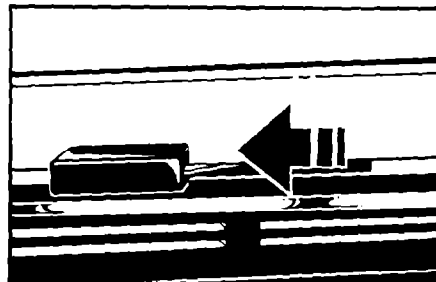

6. After the Self-Cleaning cycle is completed, the LOCKED Indicator Light will go off. Move the Lock Lever back to the left. **Do not force it.** Wait until it moves easily. Turn the Oven Selector and Oven Temperature Control to OFF.
7. After the oven is cool, wipe off any residue or ash with a damp cloth. If needed, touch up spots with a soapy steel wool pad.

Special Tips

- Keep the kitchen well ventilated during the Self-Cleaning cycle to help get rid of heat, odors and smoke.
- Clean the oven before it gets heavily soiled. Cleaning a very soiled oven takes longer and results in more smoke than usual.
- If the Self-Cleaning cycle doesn't get the oven as clean as you expected, the cycle may not have been set long enough or you may not have prepared the oven properly. Set the Self-Cleaning cycle longer the next time and hand clean areas noted on page 21.

To stop the Self-Cleaning cycle at anytime:

1. Push in and turn the Stop Time Knob **clockwise** until it points to the right time of day.
2. Turn the Oven Selector and Oven Temperature Control to OFF. When the Lock Light goes off, move the Lock Lever back to the left. **DO NOT FORCE IT.** Wait until it moves easily.

⚠ WARNING

Burn Hazard

Do not touch the range during the Self-Cleaning cycle. It can burn you.

How It Works

During the Self-Cleaning cycle, the oven gets much hotter than it does for baking or broiling...approximately 875°F (468°C). This heat breaks up grease and soil and burns it off.

This graph shows approximate temperatures and times during a Self-Cleaning cycle for 3 hours.

SELF-CLEANING CYCLE – THREE HOUR SETTING

(Approximate Temperatures and Times)

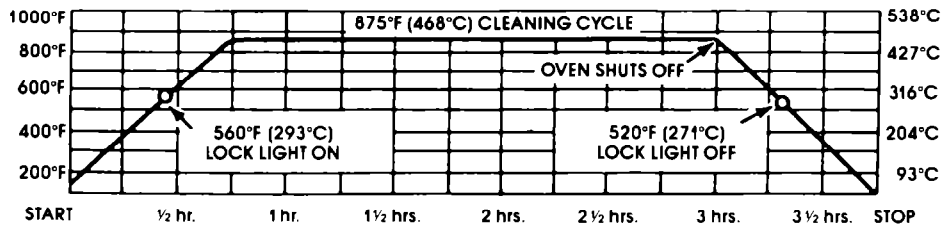

Notice that the heating stops when the 3-hour setting is up, but that it takes longer for the oven to cool down enough to unlock.

Cleaning Chart

PART	WHAT TO USE	HOW TO CLEAN
Exterior surfaces	Warm soapy water and a soft cloth. Plastic scrubbing pad for heavily-soiled areas.	<ul style="list-style-type: none"> Wipe off regularly when oven is cool. Do not allow food containing acids (such as vinegar, tomato, lemon juice or milk) to remain on surface. Acids will remove the glossy finish. Do not use abrasive or harsh cleansers.
Surface units	No cleaning required.	<ul style="list-style-type: none"> Spatters or spills will burn off. Do not immerse in water.
Porcelain-enamel reflector bowls	Warm soapy water and a plastic scrubbing pad. Self-Cleaning cycle.	<ul style="list-style-type: none"> Wipe off excess spills. Wash, rinse and dry well. Place upside down on oven racks in oven during the Self-Cleaning cycle.
Chrome trim rings	Warm soapy water and a plastic scrubbing pad.	<ul style="list-style-type: none"> Wash, rinse and dry well. Clean frequently. Do not use abrasive or harsh cleansers. Do not clean in Self-Cleaning Oven.
Control knobs	Warm soapy water and a soft cloth.	<ul style="list-style-type: none"> Wash, rinse and dry well. Do not soak.
Control panel	Warm soapy water or spray glass cleaner and a soft cloth.	<ul style="list-style-type: none"> Wash, rinse and dry well. Follow directions provided with the cleaner.
Broiler pan and grid	Warm soapy water or a soapy steel wool pad.	<ul style="list-style-type: none"> Clean after each use. Wash, rinse and dry well. Do not clean in Self-Cleaning Oven. (See note on page 21.)
Oven racks	Self-Cleaning cycle. Warm soapy water or soapy steel wool pads. NOTE: The oven racks will discolor and be harder to slide when left in the Self-Cleaning cycle. If you want them to stay shiny, remove from the oven and clean by hand.	<ul style="list-style-type: none"> Leave in oven during Self-Cleaning cycle. OR Wash, rinse and dry. Use soapy steel wool pads for heavily-soiled areas.
Oven door glass	Spray glass cleaner or warm soapy water and a plastic scrubbing pad.	<ul style="list-style-type: none"> Make sure oven is cool. Follow directions provided with the cleaner. Wash, rinse and dry well.

PART	WHAT TO USE	HOW TO CLEAN
Continuous-Cleaning Oven	Warm soapy water or a soapy steel wool pad. Heavy-duty aluminum foil or shallow pan.	<ul style="list-style-type: none">• Most fat splatters on oven walls and floor will gradually reduce to a presentably clean condition during baking.• Clean heavily-soiled areas or stains. Rinse well with water.• Place piece of foil or shallow pan, slightly larger than the cooking container, on lower rack to catch spill-overs.• Do not use commercial oven cleaners.
Self-Cleaning Oven	For areas outside the Self-Cleaning area use warm soapy water or soapy steel wool pads.	<ul style="list-style-type: none">• Follow directions starting on page 21, "Using the Self-Cleaning Cycle."• Do not use commercial oven cleaners.• Do not use foil to line the bottom of your Self-Cleaning Oven.

Using and Replacing the Light Bulbs

The Cooktop Light

The fluorescent top light is under the control panel. The Top Light Switch is on the control panel. Push it in and hold it for a few seconds to turn on the top light. Push it again to turn it off.

To Replace:

⚠ WARNING

Electrical Shock Hazard

Make sure power to the range has been turned OFF at the main power supply before replacing the fluorescent tube. Failure to do so could result in electrical shock.

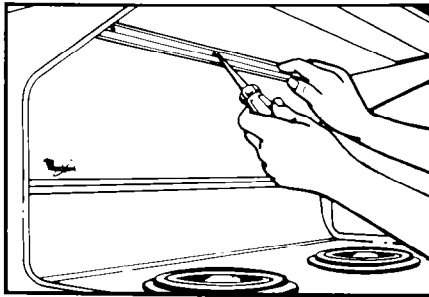

- 1.** Unplug appliance or disconnect at the main power supply. Remove the 3 screws and metal trim that supports the top of the light cover. **The glass is heavy. Hold it securely.**

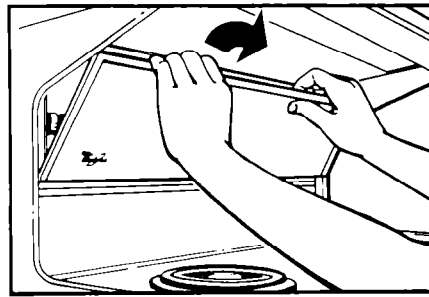

- 2.** **With both hands,** pull top of light cover towards you and lift it out of bottom support trim.

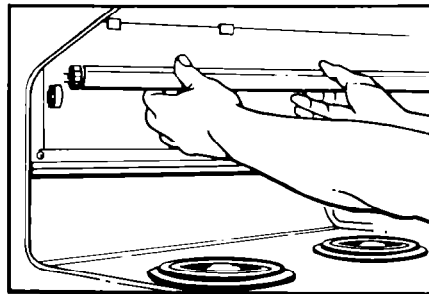

- 3.** Grasp the fluorescent tube at both ends. Roll the tube away from you until both ends come out of the receptacles. Replace with a 20-watt cool-white fluorescent tube.

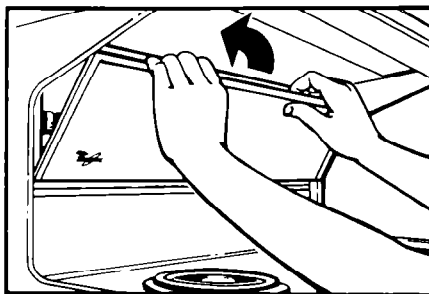

- 4.** **With both hands,** carefully fit the glass light cover into the bottom metal support trim. Then rotate the top of the light cover until it touches the contact stops. Replace the top support trim and 3 screws. Plug in appliance or reconnect at the main power supply.

The Oven Lights

Both the oven lights will come on when you open the lower oven door. To turn both lights on when the lower oven door is closed, push the Oven Light Switch on the control panel. Push it again to turn off the lights.

To Replace the Upper Oven Light:

⚠ WARNING

Electrical Shock and Burn Hazard

Make sure oven and light bulb are cool and power to the range has been turned OFF before replacing the light bulb. Failure to do so could result in electrical shock or burns.

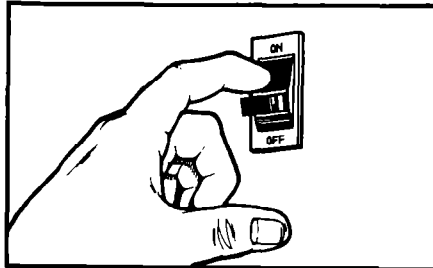

- 1.** Unplug appliance or disconnect at the main power supply.

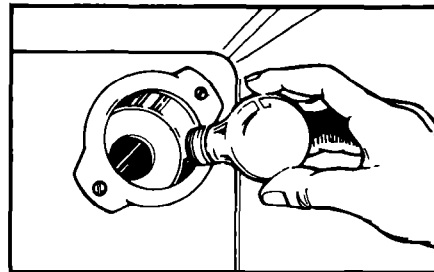

- 2.** Remove the light bulb from its socket. Replace with a 40-watt appliance bulb. Plug in appliance or reconnect at the main power supply.

continued on next page

To Replace the Lower Oven Light:

⚠ WARNING

Electrical Shock and Personal Injury Hazard

- **Make sure oven and light bulb are cool and power to the range has been turned OFF before replacing the light bulb. Failure to do so could result in electrical shock or burns.**
- **The bulb cover must be in place when using the lower oven. The cover protects the bulb from breaking and from high oven temperatures. Broken glass could cause injury.**

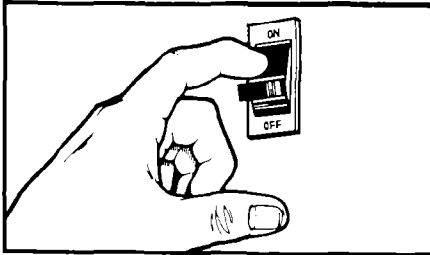

- 1.** Unplug appliance or disconnect at the main power supply.

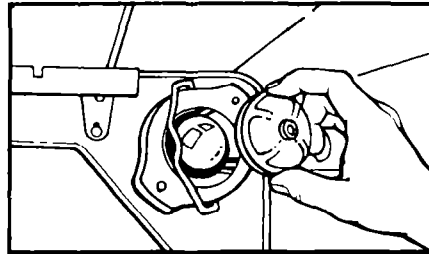

- 2.** Remove the bulb cover in the back of the oven by pulling out and pushing the wire holder to the side.

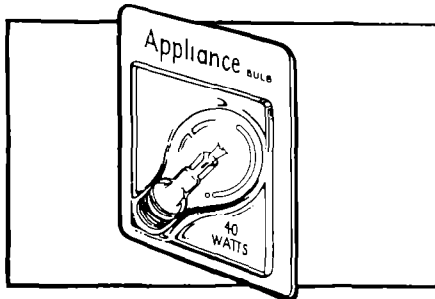

- 3.** Remove the light bulb from its socket. Replace the bulb with a 40-watt appliance bulb.

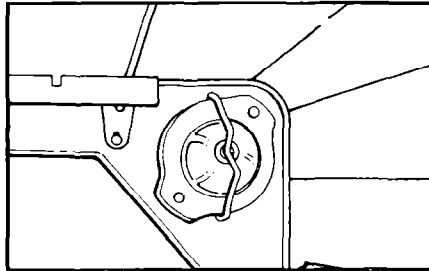

- 4.** Replace the bulb cover and snap the wire holder in place. Plug in appliance or reconnect at the main power supply.

NOTE: The oven light will not work during the Self-Cleaning cycle.

If you need service or assistance, we suggest you follow these five steps:

1. Before calling for assistance...

Performance problems often result from little things you can find and fix without tools of any kind.

If nothing operates:

- Is the power supply cord plugged into a live circuit with the proper voltage? (See Installation Instructions.)
- Have you checked your home's main fuses or circuit breaker box?

If the oven will not operate:

- Is the Oven Selector turned to a setting (BAKE or BROIL, but not TIMED)?
- Is the Oven Temperature Control turned to a temperature setting?

If surface units will not operate:

- Have you checked your home's main fuses or circuit breaker box?
- Are surface units plugged in all the way?
- Do the control knobs turn?

If surface unit control knob(s) will not turn:

- Did you push in before trying to turn?

If soil is visible on Continuous-Cleaning oven finish:

- The special finish is designed to **gradually reduce oven soil** during normal baking or roasting. It is not designed to keep your oven spotless, only presentably clean.
- If you broil often, you may see oven soil.
- The door is cooler than the oven walls. Soil will be more visible on the door than other areas in the oven. See page 20 for how to clean.
- Sugar and starchy spills may leave stains. See page 20 for hand cleaning tips. **Keep foil on oven bottom to catch these spills.**

If the Self-Cleaning cycle will not operate:

- Are the Oven Selector and Oven Temperature Control set on CLEAN?
- Does the Start Time Dial show the correct time of day?
- Is the Stop Time Dial set ahead to the time you want the cleaning cycle to stop?
- Is the Lock Lever all the way to the right?

If cooking results aren't what you expected:

- Is the range level?
- Does the oven temperature seem too low or too high? See page 10.
- If needed, have you preheated the oven as the recipe calls for?
- Are you following a tested recipe from a reliable source?
- Are you using pans recommended in the Cooking Guide?
- If baking, have you allowed 1½ to 2 inches (4-5 cm) on all sides of the pans for air circulation?
- Are the pans the size called for in the recipe?
- Do the cooking utensils have smooth, flat bottoms and fit the surface unit being used?

See the Cooking Guide for more information on cooking problems and how to solve them.

2. If you need assistance*...

Call Whirlpool COOL-LINE® service assistance telephone number. Dial free from anywhere in the U.S.:
1-800-253-1301

and talk with one of our trained consultants. The consultants can instruct you in how to obtain satisfactory operation from your appliance or, if service is necessary, recommend a qualified service company in your area.

3. If you need service*...



Whirlpool has a nationwide network of authorized WhirlpoolSM service companies. Whirlpool service technicians are trained to fulfill the product warranty and provide after-warranty service, anywhere in the United States. To locate the authorized Whirlpool service company in your area, call our COOL-LINE® service assistance telephone number (see Step 2) or look in your telephone directory Yellow Pages under:

APPLIANCES - HOUSEHOLD - ELECTRICAL APPLIANCES -
MAJOR - SERVICE & REPAIR MAJOR - REPAIRING & PARTS

OR

WASHING MACHINES, DRYERS
& IRONERS - SERVICING

WHIRLPOOL APPLIANCES
AUTHORIZED WHIRLPOOL SERVICE

SERVICE COMPANIES
XYZ SERVICE CO
123 MAPLE 999-9999

4. If you have a problem*...

Call our COOL-LINE service assistance telephone number (see Step 2) and talk with one of our consultants, or if you prefer, write to:

Mr. Donald Skinner
Director of Consumer Relations
Whirlpool Corporation
2000 M-63
Benton Harbor, MI 49022

Please include a daytime phone number in your correspondence.

5. If you need FSP® replacement parts*...

FSP is a registered trademark of Whirlpool Corporation for quality parts. Look for this symbol of quality whenever you need a replacement part for your Whirlpool appliance. FSP replacement parts will fit right and work right, because they are made to the same exacting specifications used to build every new Whirlpool appliance.

To locate FSP replacement parts in your area, refer to Step 3 above or call the Whirlpool COOL-LINE service assistance number in Step 2.

*If you must call or write, please provide: model number, serial number, date of purchase, and a complete description of the problem. This information is needed in order to better respond to your request for assistance.

WHIRLPOOL® RANGE PRODUCT WARRANTY

ER001

LENGTH OF WARRANTY	WHIRLPOOL WILL PAY FOR
FULL ONE-YEAR WARRANTY From Date of Purchase	FSP® replacement parts and repair labor to correct defects in materials or workmanship. Service must be provided by an authorized Whirlpool® service company.
WHIRLPOOL WILL NOT PAY FOR	
<p>A. Service calls to:</p> <ol style="list-style-type: none"> 1. Correct the installation of the range product. 2. Instruct you how to use the range product. 3. Replace house fuses or correct house wiring or plumbing. 4. Replace owner accessible light bulbs. <p>B. Repairs when range product is used in other than normal, single-family household use.</p> <p>C. Pick up and delivery. This product is designed to be repaired in the home.</p> <p>D. Damage to range product caused by accident, misuse, fire, flood, acts of God or use of products not approved by Whirlpool.</p>	

WHIRLPOOL CORPORATION SHALL NOT BE LIABLE FOR INCIDENTAL OR CONSEQUENTIAL DAMAGES. Some states do not allow the exclusion or limitation of incidental or consequential damages so this limitation or exclusion may not apply to you. This warranty gives you specific legal rights, and you may also have other rights which vary from state to state.

Outside the United States, a different warranty may apply. For details, please contact your franchised Whirlpool distributor or military exchange.



Part No. 3149926
©1989 Whirlpool Corporation

Printed in U.S.A.

• Makers. Dishwashers. Built-In Ovens and Surface Units. Ranges. Microwave Ovens. Trash Compactors. Room Air Conditioners. Dehumidifiers. Automatic Was

